

PAMS Technical Documentation
NSC/W-1/3 Series Transceivers

Tuning Instructions

CONTENTS

Tuning Instructions	4
General	4
Required Equipment	5
Equipment Setup	5
Equipment Setup for Tuning a Phone without Removing Covers	6
Flash Concept for NSC/W-1/3	7
Light Flash Concept for NSC/W-1/3	8
Easy Flash Concept for NSW-1/3	9
Tuning With Covers Off – Using Test-frame JBS-19	10
Tuning With Covers Off – using Light Jig JBT-1	11
Warranty Transfer	12
Warranty Transfer	12
Point of Sale	12
Central of Service	13
Point of Sale	13
Tuning Steps	14
1. AFC Tuning (Analog)	14
2. VCTCXO Tuning	14
3. Modulator Output ... LOW BAND / HIGH BAND (only NSW-1/3)	14
4. Tx I/Q Modulator Amplitude Balance and Phase Shift Tuning	15
5. TX Power... LOW BAND / HIGH BAND	16
800MHz TX output power	17
TDMA1900 TX output power	17
6. RSSI Digital (AGC)	18
7. RSSI Analog	18
8. Rx Audio...	18
9. Tx Audio...	19
10. Charging...	19

Tuning Instructions

General

All tuning operations of the NSC-1/3 and NSW-1/3 phones are carried out using the service software. The service software turns the phone into the locals mode, in which the phone can be outwardly controlled via the MBUS interface.

Tuning is based on the software communicating with the D/A and A/D converters of the phone. In some instances the phone processor will also calculate the required correction parameter.

The tuning values of the phone reside on the EEPROM. The contents of the EEPROM can be read by the service software and saved as a file. This is advisable when there is need to retain that information, e.g. in view of replacement of the circuit. The program also enables writing the default parameters on the EEPROM, in which case all tuning steps should be carried out.

Note: NSC-1 and -3 do not have upper band componets. NSC-1 and -3 are only 800 Mhz tranceivers.

During tuning, proceed as follows:

- Take care not to damage sensitive measuring instruments with excessive RF power.
- Carry out all tuning steps in the shortest possible time to avoid excessive heating of RF units.
- Perform all tuning steps in the order presented.
- Never try to mask a fault by tuning it out!

Required Equipment

- PC/AT computer with service software; see separate section for instructions on installation and use.
- Service accessories; see equipment setup pictures.
- Multimeter or DVM.
- GSM radio telephone test station or separate measuring equipment as follows:
 - RF generator
 - pulse power meter
 - spectrum analyzer
 - attenuator and branching unit

Equipment Setup

Caution: Make sure that you have switched off the PC and the printer before making connections !

Caution: Do not connect the PKD-1 key to the serial port. You may damage your PKD-1 !

Attach the protection key PKD-1 to parallel port one (25-pin female D-connector) of the PC. When connecting the PKD-1 to the parallel port be sure that you insert the PC end of the PKD-1 to the PC (male side). If you use a printer on parallel port one, place the PKD-1 between the PC and your printer cable.

Next connect the M2BUS service cable, DAU-9P, to the serial port (RS-232) of the computer. Attach one end of the service cable to the PC serial port and the other end to the service box, JBA-4. For servicing the phone with the covers in place the service box should always be used.

When the phone covers are removed the jigs should be used.

For audio measurements connect the audio cable, ADS-1, as follows:

- EAR line to AF INPUT of test equipment
- MIC line to MOD GEN OUTPUT of test equipment

Equipment Setup for Tuning a Phone without Removing Covers

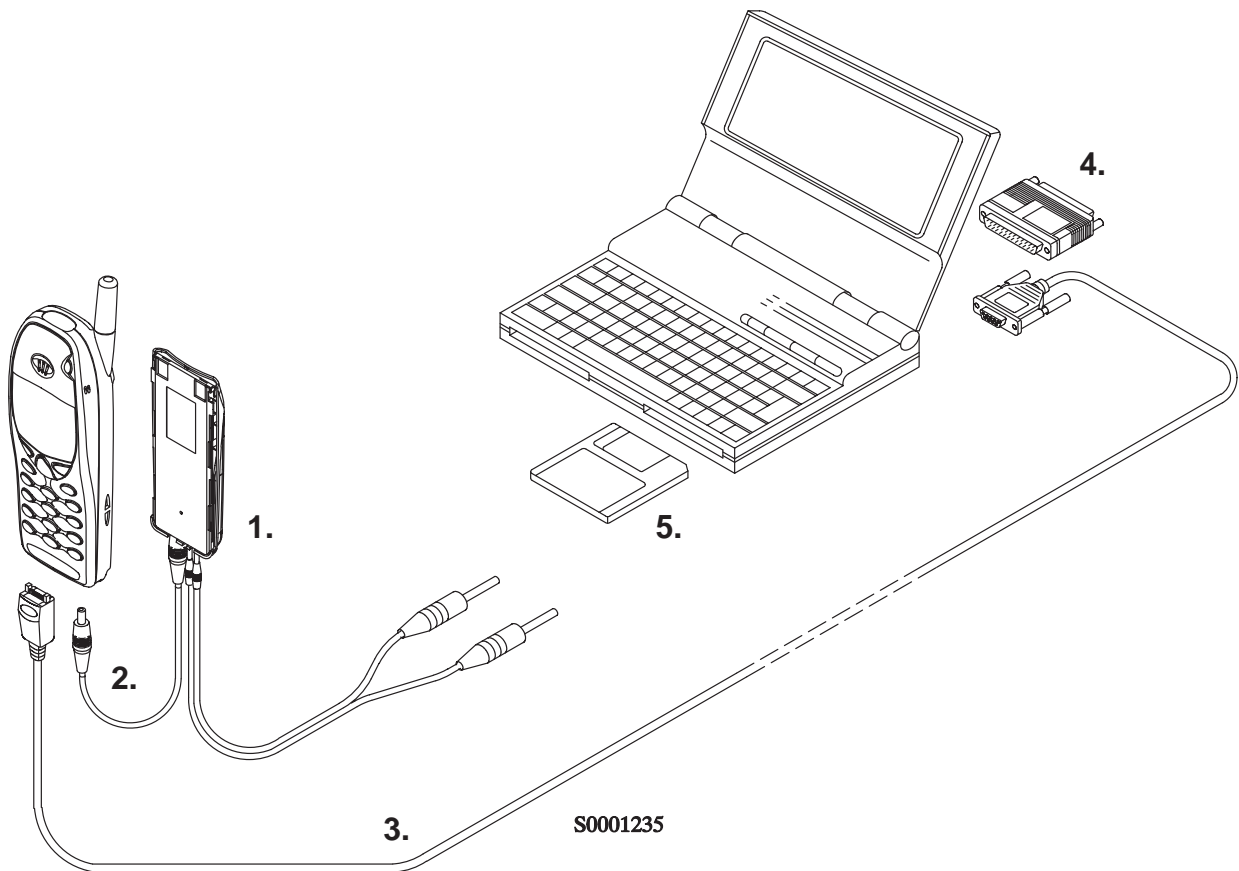

Item:	Service accessory:	Product code:
1	Service Battery BBD-3	0775071
2	DC Cable SCB-3	0730114
3	Service MBUS Cable DAU-9P	0730109
4	Software protection key PKD-1	0750018
5	Service SW diskette 3.5" for NSC/W-1/3	0774099
	WinTesla Service SW application	0774046

Flash Concept for NSC/W-1/3

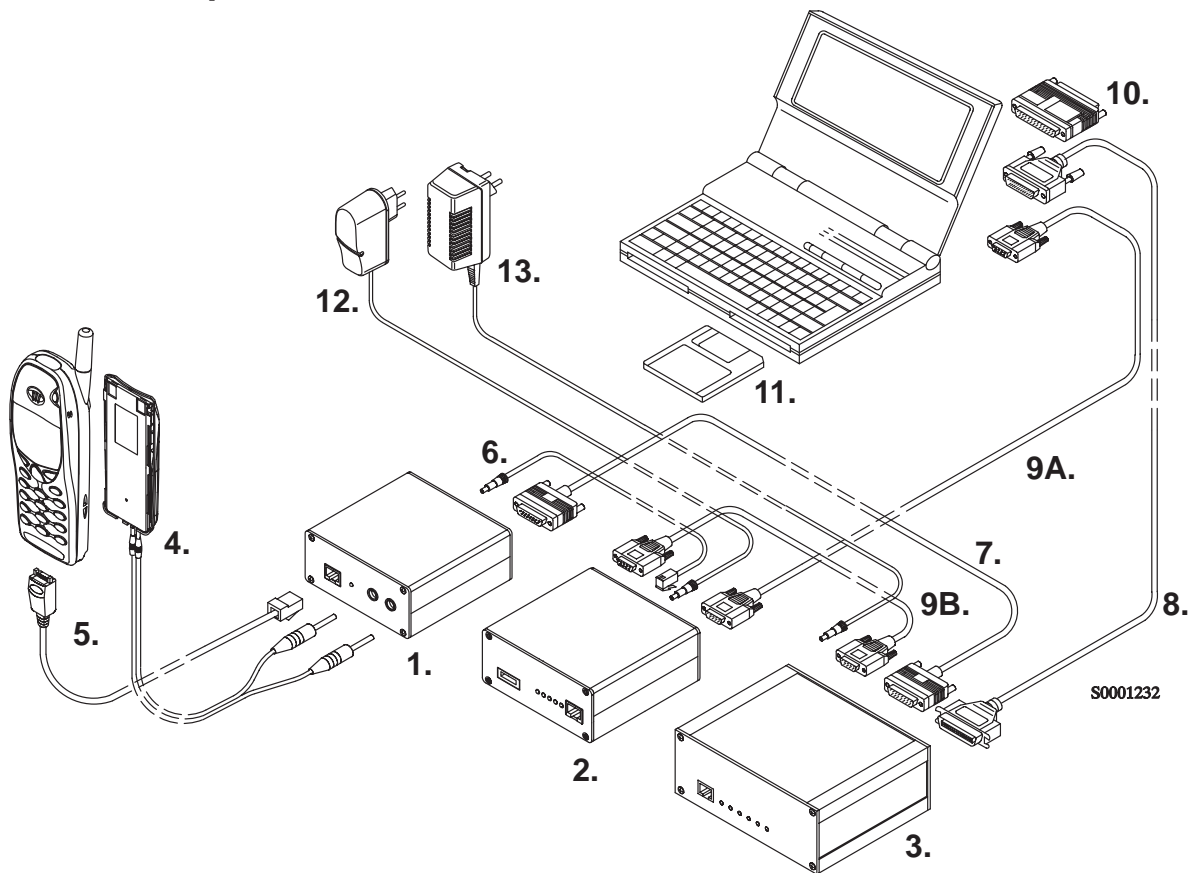

Item:	Service accessory:	Product code:
1	Flash Loading Adapter FLA-5	0080178
2	Flash Security Box TDF-4	0770106
3	Prommer FPS-4S	0085095
4	Service Battery BBD-3	0775071
5	Service Cable SCH-5	0730098
6	DC Cable PCC-1B	0730053
7	D15 – D15 Cable AXS-5 (Included in FLA-5 sales pack)	0730091
8	Printer Cable (Included in FPS-4 sales pack)	0730029
9A	D9 – D9 Cable AXS-4 (Included in FPS-4 sales pack)	0730090
9B	D9 – D9 Cable AXS-4	0730090
10	Software protection key PKD-1	0750018
11	Service SW diskette 3.5" for NSC/W-1/3 WinTesla Service SW application	0774099 0774046
12	Travel Charger ACH-6E (Euro)	0270381
	Travel Charger ACH-6U (USA/Japan)	0270382
	Travel Charger ACH-6X (UK)	0270380
13	AC Charger ACL-3E (Included in FPS-4 sales pack)	0680015

Light Flash Concept for NSC/W-1/3

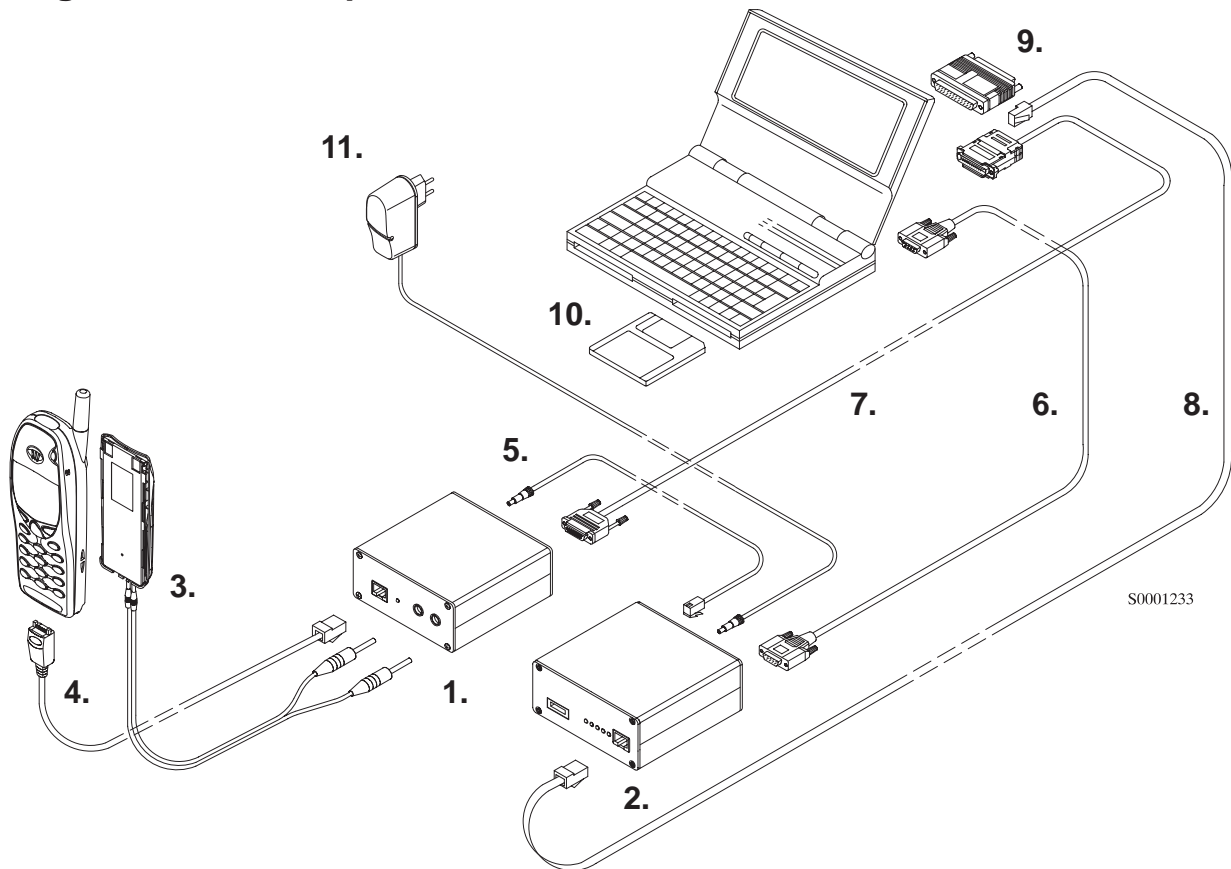

Item:	Service accessory:	Product code:
1	Flash Loading Adapter FLA-5	0080178
2	Flash Security Box TDF-4	0770106
3	Service Battery BBD-3	0775071
4	Service Cable SCH-5	0730098
5	DC Cable PCC-1	0730053
6	D9 - D9 Cable AXS-4	0730090
7	Light Flash Cable FLC-5	0770107
8	XCM-1 Cable	4626131
9	Software protection key PKD-1	0750018
10	Light Flash SW diskette 3.5" for NSB/C/W-1/3	0774094
11	Travel Charger ACH-6E (Euro)	0270381
	Travel Charger ACH-6U (USA/Japan)	0270382
	Travel Charger ACH-6X (UK)	0270380

Easy Flash Concept for NSW-1/3

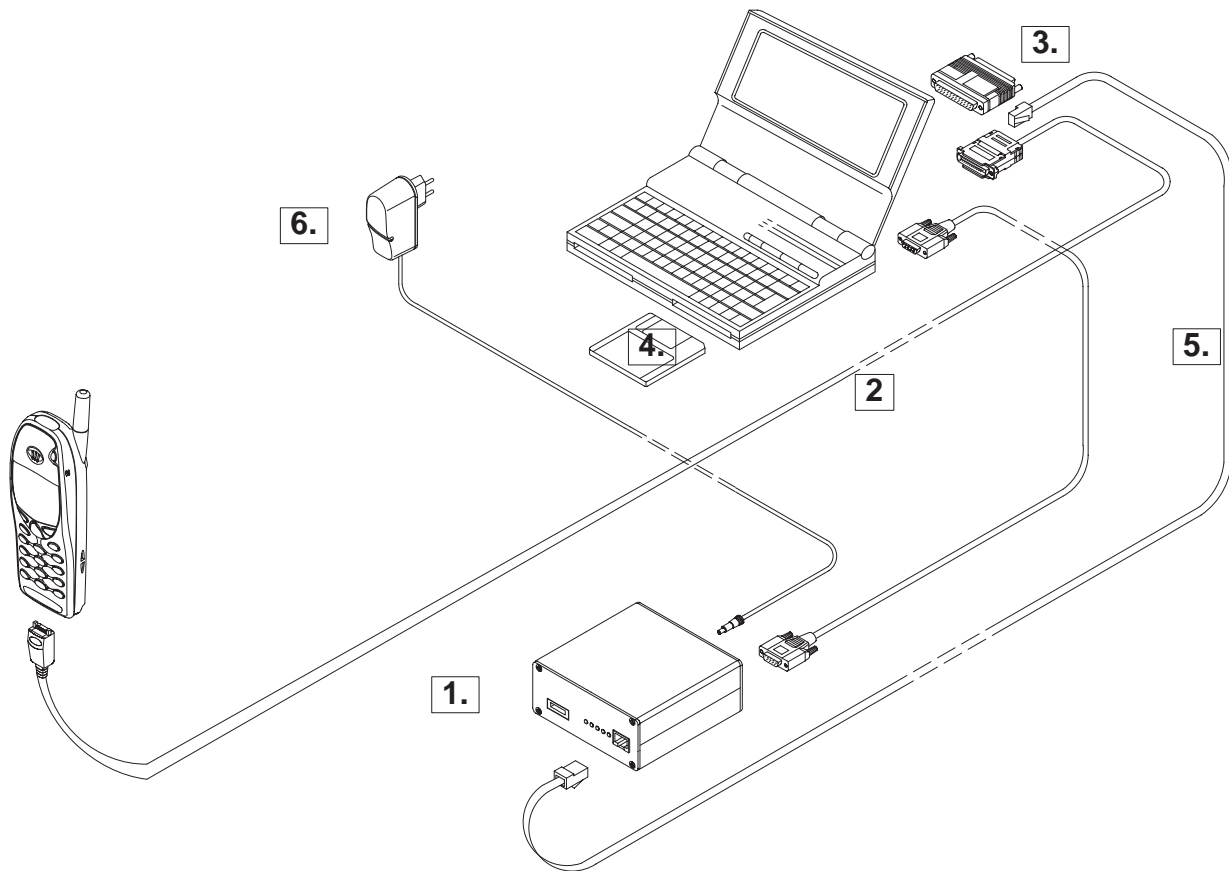

Item:	Service accessory:	Product code:
1	Flash Security Box TDF-4	0770106
2	Easy Flash Cable FLE-5	0770147
3	Software protection key PKD-1	0750018
4	Easy Flash SW diskette 3.5" for NSW-1/3	
5	XCM-1 Cable	4626131
6	Travel Charger ACH-6E (Euro)	0270381
	Travel Charger ACH-6U (USA/Japan)	0270382
	Travel Charger ACH-6X (UK)	0270380

Tuning With Covers Off – Using Test-frame JBS-19

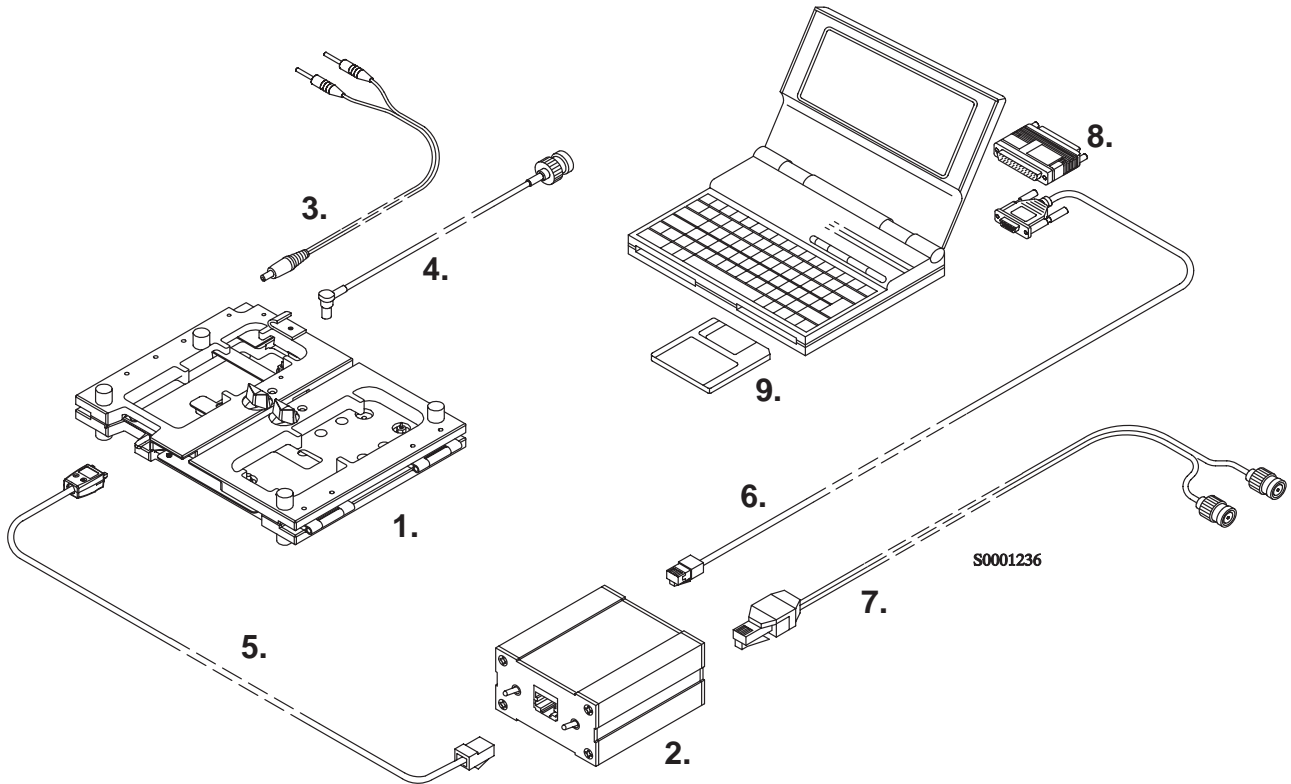

Item:	Service accessory:	Product code:
1	Module Jig JBS-19 *	0770098
2	Service Audio Box JBA-4 **	0770094
3	DC Cable PCS-1	0730012
4	External Antenna Cable XRC-1B	0730128
5	Service Cable SCH-5 **	0730098
6	Service MBUS Cable DAU-9S **	0730108
7	Audio Cable ADS-1	0730011
8	Software Protection Key PKD-1	0750018
9	Service SW diskette 3.5" for NSC/W-1/3	0774099
	WinTesla Service SW application	0774046

*) The nominal operating voltage for JBS-19 is 3.6 V.
The supply voltage for JBS-19 must never exceed 5.0 V

**) SCH-5, JBA-4, and DAU-9S can be replaced with DAU-9P

Tuning With Covers Off – using Light Jig JBT-1

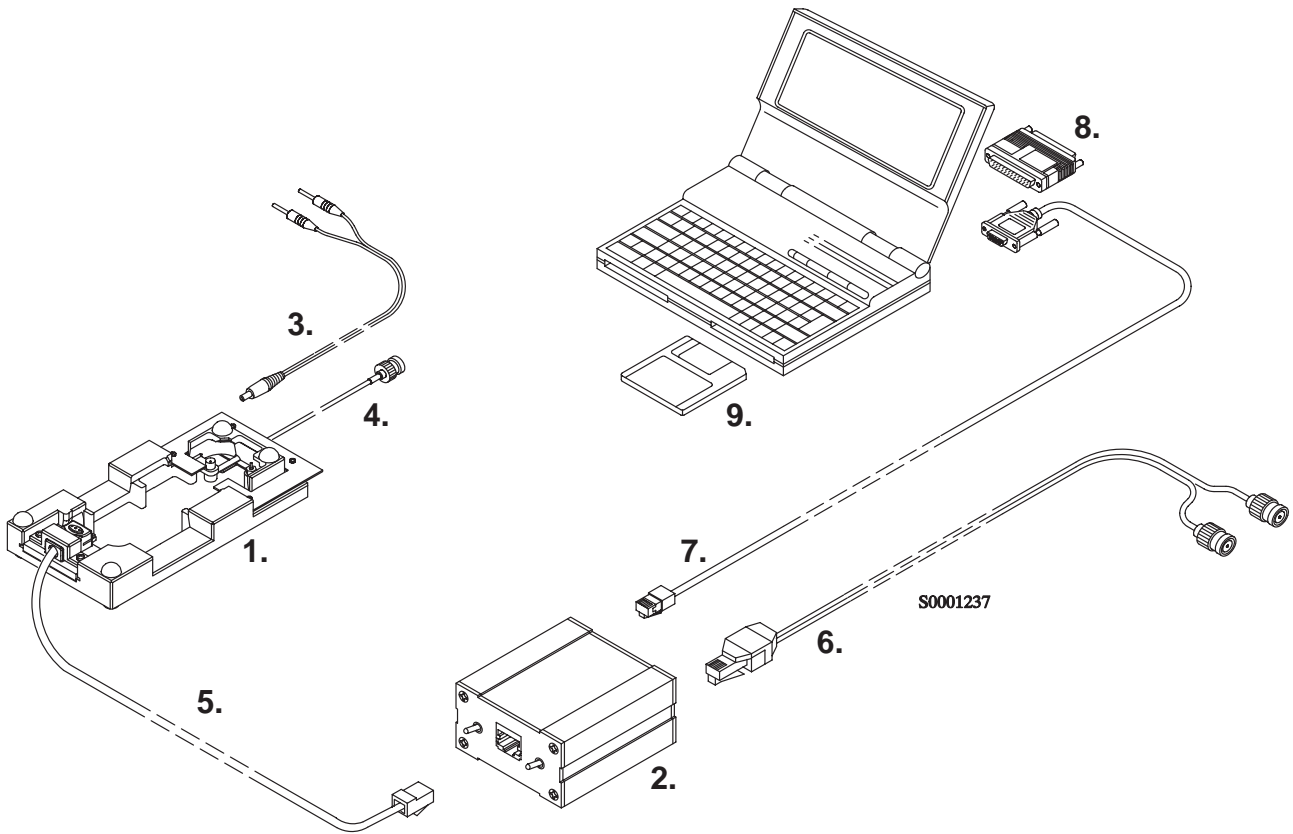

Item:	Service accessory:	Product code:
1	Light Module Jig JBT-1 *	0770109
2	Service Audio Box JBA-4 **	0770094
3	DC Cable PCS-1	0730012
4	External Antenna Cable XRC-1B	0730128
5	Service Cable SCH-5 **	0730098
6	Audio Cable ADS-1	0730011
7	Service MBUS Cable DAU-9S **	0730108
8	Software Protection Key PKD-1	0750018
9	Service SW diskette 3.5" for NSC/W-1/3	0774099
	WinTesla Service SW application	0774046

*) The nominal operating voltage for JBT-1 is 3.6 V.
The supply voltage for JBT-1 must never exceed 5.0 V

**) SCH-5, JBA-4, and DAU-9S can be replaced with DAU-9P

Warranty Transfer

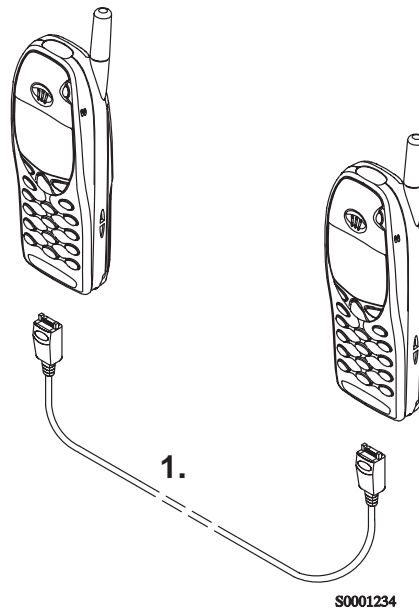

Item:	Service accessory:	Product code:
1	Warranty Cable SCH-6	0730099

Warranty Transfer

The Warranty cable SCH-6 is used to connect two phones and transfer the warranty data (user settings and serial numbers) from one phone to another.

The warranty transfer procedure is as follows

Point of Sale

- Phone 1 is broken.
- Number the phones 1 and 2 to avoid mix-up.
- Plug the warranty cable SCH-6 to the phones. In this case phones 1 and 2.
- Turn the phone 2 on and then on Silent Profile
- Start the warranty data transfer by selecting code ***#92772689#** in phone 2.
- Select option **"Transfer user data?"** and press OK ,**"Confirm transfer?"** Press OK.
- Wait until the transfer is completed.
- Turn Phone 2 off, then back on and check welcome note and profile.

- After the transfer check with WinTesla the original and warranty ESN of the phone 2.
- Send the broken phone no.1 to the central service.

Central of Service

- Check and repair the phone .
- Change Warranty State from "defective" to "exchange".
- –Win Tesla and PKD-1CS are needed
- –Menu Software -> Warranty Info -> Info State -> select "Exchange"
- Send the repaired phone to the dealer.

Point of Sale

- Use the returned phone as a swap phone.
- When the Warranty Info is transferred into a swap phone the Warranty State changes to USE mode.
- Send the broken phone to the central service.

Tuning Steps

1. AFC Tuning (Analog)

This tuning adjusts reference oscillators frequency so that network's frequency criterias will be met.

This adjustment loads the Analog center frequency DAC value into the EEPROM. When doing this, a spectrum analyzer must be used.

Note: Do not leave tuning on. The analog transmitting takes maximum current. The tuning can damage the phone or service battery. The service battery will be heated.

The Spectrum analyzer settings are shown in AFC tuning window.

- Set power supply voltage 8.4 V to service battery (or 3.6 V to jig).
- Connect the spectrum analyzer to antenna connector.
- Check that spectrum analyzer frequency is correct.
- Tune the center frequency 832.500 Mhz +/- 200 kHz.
- Once Center frequency (CFR) is correct, press *OK* button.

2. VCTCXO Tuning

This tuning is to check that the radio unit has correct adjustment to meet networks criteria for frequency stability.

This adjustment loads the VCTCXO DAC value into the EEPROM. RF generator must be used in this.

The Spectrum analyzer settings are shown in AFC tuning window.

- Set power supply voltage 8.4 V to service battery (or 3.6 V to jig).
- Connect the antenna connector to RF generator.
- Once all RF generator frequency is correct, press *Meas button*.
- Set correct RF level to signal generator (*Note: attenuation!*)
- Once frequency and RF level are correct press *OK* button.

3. Modulator Output ... LOW BAND / HIGH BAND (only NSW-1/3)

This tuning is to adjust radio unit's intermediate frequency level so that RF small signal gain have it's maximum dynamic range in use with some drift margin.

- Select *Tuning* → *Modulator output* → *Low Band / High Band*
- Set power supply voltage 8.4 V to service battery (or 3.6 V to jig).

- Connect pulse power meter or spectrum analyzer to antenna connector.
- Check that spectrum analyzer frequency is correct (RF information shows correct frequency)
- Tune the modulator output power to 22dBm.
- Once tuning level is correct, press *OK* button.

4. Tx I/Q Modulator Amplitude Balance and Phase Shift Tuning

This tuning is to adjust I/Q-modulators dc-offset and phase error so that system's requirements for modulation accuracy will be met.

The purpose of this tuning operation is to adjust the I/Q modulator d.c. offsets and the I/Q modulator amplitude balance and phase shift.

I/Q modulator d.c. offsets, amplitude balance and phase shift tuning:

- Select *Tuning* → *TX I/Q...*
- Connect spectrum analyzer (with attenuator if needed) to phone antenna connector.
- Check that TX power level is level 10, channel is 60 and TX data type is 1.
- Adjust spectrum analyzer centre frequency to 830.700 Mhz, and all other settings are notified by pressing <Settings>.

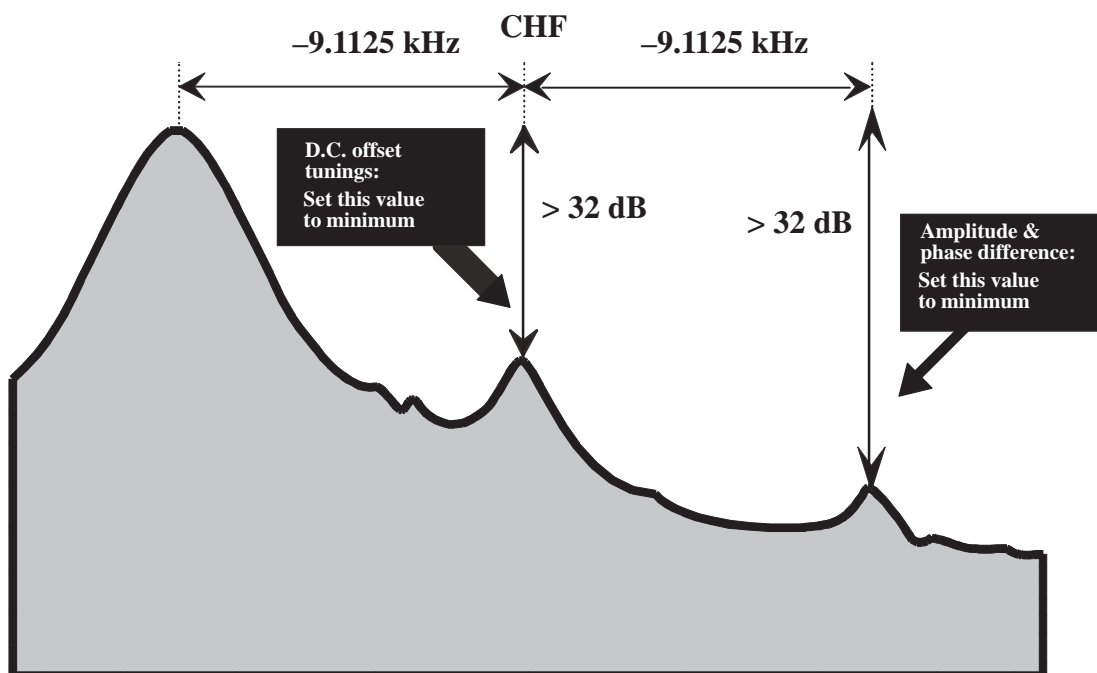

- Select the "TX I d.c. offset" option.
- Adjust the level of centre frequency (CHF signal) to minimum by varying D/A converter value with <- and -> buttons.

- The amplitude difference between CHF –9.1125 kHz and CHF should be >30 dB.
- Select option "TX Q d.c. offset".
- Adjust the level of signal CHF to minimum by varying D/A converter value with <- and -> keys.
- Use the "Amplitude Difference" option.
- Adjust the level of signal CFR –9.1125 kHz to minimum by varying D/A converter value with <- and -> keys.
- The amplitude difference between CHF+67.7 kHz and CHF –67 kHz should be >35 dB.
- Select the "Phase Difference" option.
- Adjust the level of signal CHF+67.7 kHz to minimum by varying D/A converter value with <- and -> keys.
- When values are correct press SAVE button.

5. TX Power... LOW BAND / HIGH BAND

NOTE: Use Service Battery connected to 1.5A 8.4V power supply or use phone's own battery.

This tuning is to adjust radio unit's output power level values according to system specification.

This adjustment loads the power levels of the phone transmitter into the EEPROM. When doing this, a pulse power meter or spectrum analyzer must be used.

The <Settings> shows spectrum analyzer settings.

Power levels programming:

-
- Select Tuning -> TX Power... ->LOW BAND / HIGH BAND
 - All power channel have to be tuned. Repeat this test for A, B, C and D power channel. The Power channel change read old tuning values from phone's EEPROM.
 - Set power supply voltage 8.4 V to service battery (or 3.6 V to jig).
 - Connect pulse power meter or spectrum analyzer to antenna connector.
 - Check that spectrum analyzer frequency is correct.
 - Adjust the power level by clicking the + and – buttons, and change levels with ↑ and ↓ keys.
 - Tune levels which are shown by # for calculate.
 - Press Calculate button to calculate all other levels.
 - Once all TX levels are correct, press SAVE button.

800MHz TX output power

Power level	RF Power at ext. RF connector (*)
2	26.8 dBm (analog 26.15 dBm)
3	23.5 dBm
4	19.8 dBm
5	15.8 dBm
6	11.8 dBm
7	7.8 dBm
8	3.8 dBm
9	-0.2 dBm
10	-4.2 dBm

Check, that power level PL2 TXC value is on allowed range -50...200.

(* If there is a difference between power measured from panel test pad and ext RF connector, this must be taken care so that measurements from ext. RF give the correct results.

TDMA1900 TX output power

Power level	RF Power at ext. RF connector (*)
2	25.8 dBm (600 mW)
3	22.2 dBm
4	18.4 dBm
5	14.6 dBm
6	10.8 dBm
7	7.0 dBm
8	3.4 dBm
9	-0.2 dBm
10	-4.2 dBm

Check, that power level PL2 TXC value is on allowed range -10...+350.

(* If there is a difference between power measured from panel test pad and ext RF connector, this must be taken care so that measurements from ext. RF give the correct results.

6. RSSI Digital (AGC) ...

This tuning is to measure the small signal gain of radio unit to meet system requirements for RSSI reporting.

- Select *Tuning* → *RSSI Digital (AGC)* → *Low Band / High Band*
- Set power supply voltage 8.4 V to service battery (or 3.6 V to jig).
- Connect the RF generator to antenna connector.
- Press *Meas* → The program shows correct frequency and signal level.
- Once RF generator setting are correct, press *OK* button
- Repeat measurement with all signal levels.
- Once tuning is correct, press *OK* button.

7. RSSI Analog ...

This measurement is for RSSI in analog mode. The analog mode works only with 800 Mhz.

- Select *Tuning* → *RSSI Analog...*
- Set power supply voltage 8.4 V to service battery (or 3.6 V to jig).
- Connect the RF generator to antenna connector.
- Press *Meas* → The program shows correct frequency and signal level.
- Once RF generator setting are correct, press *OK* button
- Repeat measurement with all signal levels.
- Once tuning is correct, press *OK* button.

8. Rx Audio...

This measurement is for Audio output calibration for DAMPS mode. When doing this the oscilloscope or multimeter must be used.

- Select *Tuning* → *RX Audio*
- Connect the XEAR line to oscilloscope or multimeter.
- tune the signal to correct level
- Once tuning is correct, press *OK* button

9. Tx Audio...

This measurement is for Audio output calibration for DAMPS mode.
When doing this the signal generator must be used.

- Select *Tuning* → *RX Audio*
- Connect the XMIC line to signal generator.
- tune the signal to correct level
- Once tuning is correct, press *OK* button

10. Charging...

- Select *Tuning* → *Charging...*
- Connect service battery to phone and dc cable (SCB-3)
between phone and service battery
- Set supply voltage to 10.5 V
- Run calibrations all at once
- Run calibrations by pressing <MEAS> button
- Set supply voltage back to 8.4 V

This page intentionally left blank.

[] 1